

Inherited missense variants that affect GFI1B function do not necessarily cause bleeding diatheses

Several types of *GFI1B* variants have been identified in patients with inherited bleeding and platelet disorders. This includes dominant-negative truncating variants affecting DNA binding,¹⁻⁴ missense variants of which the molecular mechanism is unclear,⁵⁻⁷ and variants changing the amount and ratio of GFI1B isoforms (*Online Supplementary Figure S1*).^{7,8} The severity of the bleeding disorder may differ depending on the type of variant, but frequent abnormalities include macrothrombocytopenia, a reduction in alpha (α)-granule numbers, and platelet CD34 expression. In this study, we performed a molecular and/or clinicopathological characterization of eight GFI1B variants located in non-DNA binding domains (*Online Supplementary Figure S1*). These variants had been previously identified by the NIH Rare Disease Study in cases with an assumed inherited bleeding or platelet disorder.⁹ Molecular characterization was not performed for D23N since the minor allele frequency in

the gnomAD database was considered too high for a causal variant. From the characterization of the other variants, we can conclude that, although some have a clear effect on GFI1B function, they are not necessarily sufficient to cause a bleeding predisposition on their own.

We previously used the megakaryoblast cell line MEG-01 to study the effect of GFI1B and the proven pathogenic GFI1B-Q287* variant on cell expansion. In expansion-competition cultures containing transduced and non-transduced cells, MEG-01 cells ectopically expressing GFI1B were overgrown by non-transduced cells, while the opposite was observed following expression of GFI1B-Q287* (Figure 1).¹⁰ Thus, forced GFI1B expression inhibits MEG-01 cell expansion whereas dominant-negative GFI1B-Q287* results in enhanced expansion. The latter is in line with elevated megakaryocyte numbers observed in a bone marrow specimen of an individual presenting the GFI1B p.Q287* variant.¹ To investigate the functional effect of GFI1B variants, they were retrovirally expressed in MEG-01 cells and tested in the expansion-competition culture described above. GFI1B and GFI1B-

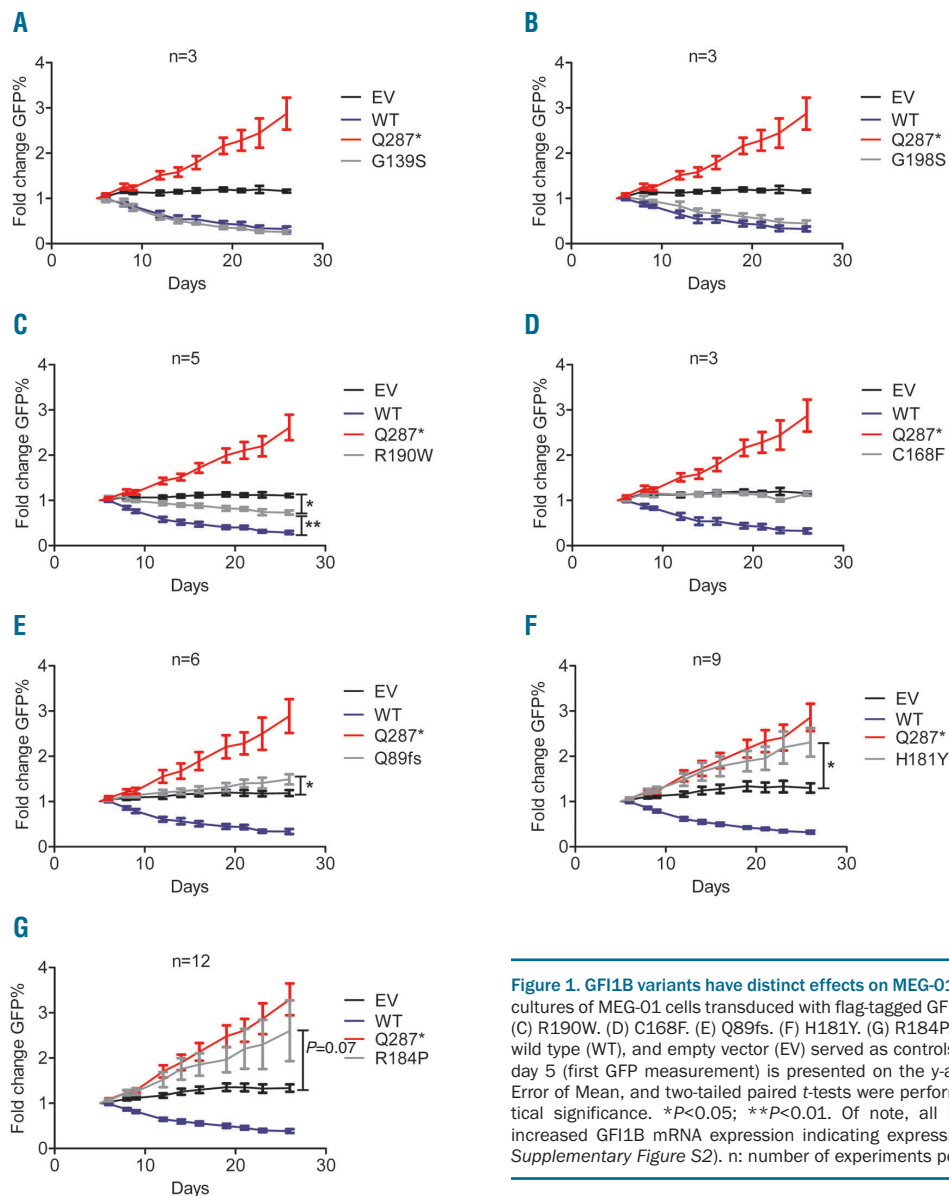

Figure 1. GFI1B variants have distinct effects on MEG-01 expansion. Expansion competition cultures of MEG-01 cells transduced with flag-tagged GFI1B variants. (A) G139S. (B) G198S. (C) R190W. (D) C168F. (E) Q89fs. (F) H181Y. (G) R184P. GFI1B-Q287*-flag, GFI1B-p37-flag wild type (WT), and empty vector (EV) served as controls. Fold change of GFP% to GFP% at day 5 (first GFP measurement) is presented on the y-axis. Results show Mean±Standard Error of Mean, and two-tailed paired t-tests were performed on day 26 to determine statistical significance. * $P<0.05$; ** $P<0.01$. Of note, all MEG-01 transduced cells showed increased GFI1B mRNA expression indicating expression of the retroviral vector (*Online Supplementary Figure S2*). n: number of experiments performed.

Q287* were used as references. Two variants, one in the intermediate domain (G139S) and one in zinc finger (znf) 2 (G198S), did not affect the inhibitory function of wild-type (WT) GFI1B on MEG-01 proliferation (Figure 1A and B). The R190W variant, located between znf1 and znf2, made the protein less effective at inhibiting MEG-01 proliferation (Figure 1C), while both the znf1 variant C168F and the truncated variant Q89fs made the protein completely inactive (Figure 1D and E). Interestingly, expression of znf1 H181Y and R184P variants resulted in increased MEG-01 cell proliferation, although to a lesser extent than cells expressing GFI1B-Q287* (Figure 1F and G). To further study H181Y and R184P, we introduced these variants separately in GFI1B-Q287*. This led to partial inhibition of the growth stimulating effect of GFI1B-

Q287* (Figure 2A and B), indicating that amino acids H181 and R184 are important for the effect of GFI1B-Q287* on MEG-01 proliferation. These findings clearly demonstrate that different variants distinctively impact the qualitative function of GFI1B, and that znf1 is important in regulating MEG-01 proliferation.

The increased MEG-01 expansion caused by GFI1B-H181Y and GFI1B-R184P suggests that these variants, like GFI1B-Q287*, act in a dominant-negative manner. However, the molecular mechanism might be different, because these variants are not located in the DNA binding domain in contrast to GFI1B-Q287*. GFI1B is a repressive transcription factor that inhibits its own transcription and that of its paralog *GFI1*.^{11,12} GFI1B-Q287* does not possess this repressive function.¹ To study if the

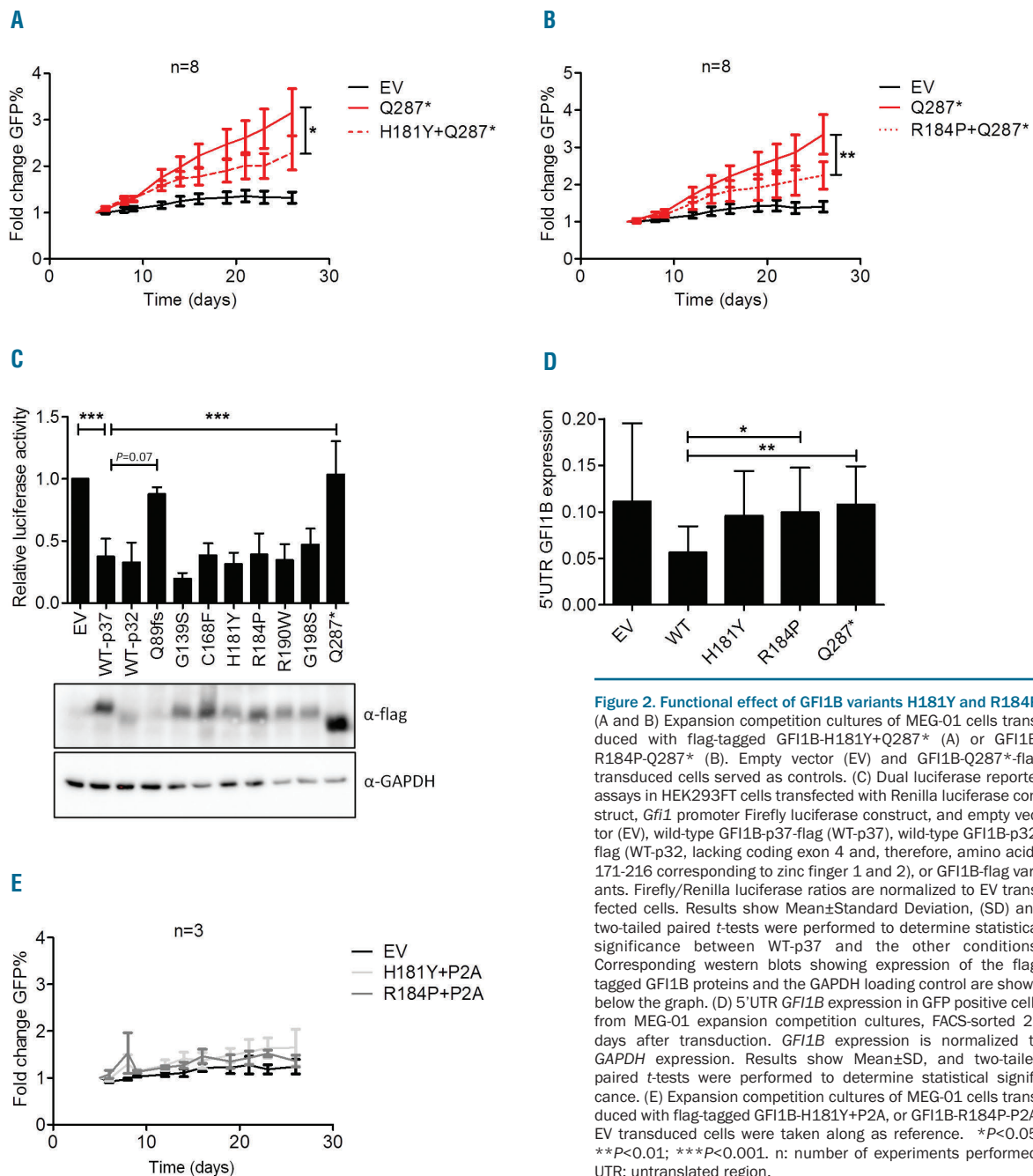

Figure 2. Functional effect of GFI1B variants H181Y and R184P.

(A and B) Expansion competition cultures of MEG-01 cells transduced with flag-tagged GFI1B-H181Y+Q287* (A) or GFI1B-R184P-Q287* (B). Empty vector (EV) and GFI1B-Q287*-flag transduced cells served as controls. (C) Dual luciferase reporter assays in HEK293FT cells transfected with Renilla luciferase construct, *Gfi1* promoter Firefly luciferase construct, and empty vector (EV), wild-type GFI1B-p37-flag (WT-p37), wild-type GFI1B-p32-flag (WT-p32, lacking coding exon 4 and, therefore, amino acids 171-216 corresponding to zinc finger 1 and 2), or GFI1B-flag variants. Firefly/Renilla luciferase ratios are normalized to EV transfected cells. Results show Mean±Standard Deviation, (SD) and two-tailed paired t-tests were performed to determine statistical significance between WT-p37 and the other conditions. Corresponding western blots showing expression of the flag-tagged GFI1B proteins and the GAPDH loading control are shown below the graph. (D) 5'UTR *GFI1B* expression in GFP positive cells from MEG-01 expansion competition cultures, FACS-sorted 23 days after transduction. *GFI1B* expression is normalized to GAPDH expression. Results show Mean±SD, and two-tailed paired t-tests were performed to determine statistical significance. (E) Expansion competition cultures of MEG-01 cells transduced with flag-tagged GFI1B-H181Y+P2A, or GFI1B-R184P+P2A. EV transduced cells were taken along as reference. * $P < 0.05$; ** $P < 0.01$; *** $P < 0.001$. n: number of experiments performed; UTR: untranslated region.

variants affect the repressive function of GFI1B, we performed gene reporter assays using the *Gfi1* promoter. Remarkably, all tested GFI1B missense variants, including GFI1B-H181Y and GFI1B-R184P, repressed the *Gfi1* promoter to a similar extent as WT GFI1B (Figure 2C). However, results obtained in transient gene repression assays may not reflect effects on endogenous target genes. Therefore we analyzed the effects of GFI1B-H181Y and GFI1B-R184P on endogenous *GFI1B* expression. WT GFI1B, GFI1B-Q287*, GFI1B-H181Y, and GFI1B-R184P were expressed in MEG-01 cells, followed by endogenous GFI1B mRNA expression analysis. In line with earlier reports, WT GFI1B inhibited endogenous *GFI1B* expression.¹⁵ In contrast, GFI1B-Q287*, as well as GFI1B-H181Y and GFI1B-R184P, did not repress endogenous GFI1B expression to the same extent as WT GFI1B (Figure 2D). This indicates that not only the DNA binding znfs, but also amino acids H181 and R184 are required for efficient repression of endogenous GFI1B.

The LSD1-RCOR1-HDAC co-repressor complex is one of the main epigenetic regulatory complexes recruited by GFI1B to induce transcriptional repression. To study whether GFI1B-H181Y-induced and GFI1B-R184P-

induced MEG-01 expansion depends on an interaction with this complex, we co-introduced a P2A mutation in the GFI1B-H181Y or GFI1B-R184P variants. The P2A mutation in the N-terminal SNAG domain of GFI1B abrogates its interaction with LSD1¹⁴ and nullifies the inhibitory effect of WT GFI1B and stimulatory effect of GFI1B-Q287* on MEG-01 proliferation.¹⁰ Expression of the P2A-H181Y and P2A-R184P double mutants resulted in expansion rates similar to those of empty vector transfected cells (Figure 2E). This strongly suggests that H181Y and R184P variants require the LSD1 interaction to exert their stimulating effect on MEG-01 expansion.

The functional data were subsequently correlated with clinical data and laboratory features of patients' samples to improve classification of the GFI1B variants according to the guidelines of the American College of Medical Genetics and genomics (ACMG)¹⁵ (Online Supplementary Table S1). A minimal set of genetic, clinical and laboratory features has already been published by Chen *et al.*⁹ (Online Supplementary Table S1). For this study, we expanded clinical and laboratory phenotype studies for the H181Y and R184P variants, because these GFI1B variants had similar effects on function in the MEG-01 cell

A

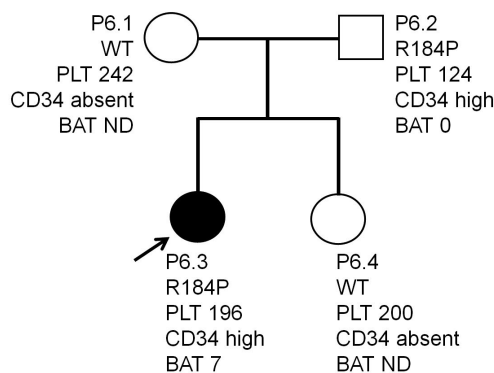

B

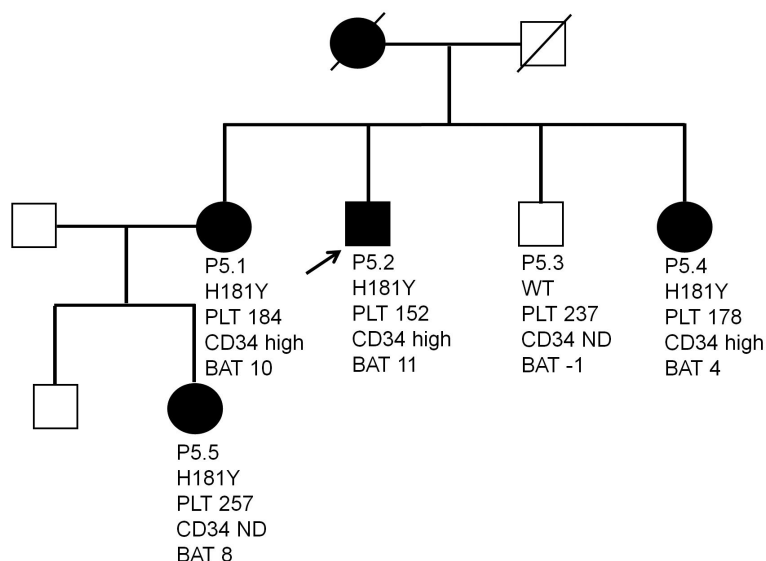

Figure 3. Pedigrees for families harboring GFI1B variants H181Y (A) and R184P (B). The proband (arrow) and the family members with signs of pathological bleeding are indicated with a black filled symbol. Males are indicated with squares, and females with circles. GFI1B variant status, patient identifier, GFI1B variant status, platelet count (PLT), CD34 expression, and the International Society on Thrombosis and Hemostasis Bleeding Assessment Tool (ISTH-BAT) score are indicated for each patient. Normal range for the ISTH-BAT score is <4 in adult males, <6 in adult females, and <3 in children. P5.4 has less hemostatic challenges than the other siblings. ND: not determined. Additional clinical and laboratory data obtained in patients' samples are available in Online Supplementary Table S1.

models as the proven pathogenic GFI1B-Q287* variant. In addition, we performed clinical and laboratory phenotype studies for R190W variant carriers.

The variants G139S and G198S were classified as 'Benign' as they showed similar inhibition of MEG-01 expansion to WT GFI1B, and have a relatively high minor allele frequency in gnomAD. Furthermore, the thrombocytopenia in patient P9 with G198S was explained by a pathogenic ACTN1 variant (p.R46Q).¹⁶ Variants R190W, C168F and Q89fs did not inhibit MEG-01 expansion to the same extent as WT GFI1B (loss of function effect). R190W platelets were weakly CD34-positive, but R190W in patients P8.1 and P8.2 did not co-segregate with bleeding or result in abnormal α -granules (*Online Supplementary Table S1* and *Online Supplementary Figures S3-S5*). Moreover, patient P7 with the same R190W variant was explained by a pathogenic variant in WAS (p.R364*), resulting in a 'Benign' classification for R190W. Patient P4 with a homozygous C168F variant suffered from clinical bleeding symptoms with thrombocytopenia and platelet aggregation dysfunction. Unlike P4, heterozygous C168F patients studied by Rabbolini *et al.* only displayed macrothrombocytopenia with platelet CD34 expression (partial effect on the phenotype).⁷ C168F is predicted to disrupt znf1 structure and thereby GFI1B function.⁹ This was confirmed in functional experiments performed here (Figure 1D) and by Rabbolini *et al.* showing that C168F disrupts the repressive function of GFI1B gene expression.⁷ C168F was classified as a 'variant of unknown significance' (VUS); further studies in the affected patient or of family members were not possible. A 90-year old woman (deceased) carrying the Q89fs variant and without affected siblings had mild thrombocytopenia with bleeding, platelet dysfunction and significantly reduced α -granule numbers; a phenotype very similar to previously described GFI1B pathogenic variants (*Online Supplementary Table S1* and *Online Supplementary Figure S5*).^{1,2,4} The Q89fs variant does not repress the Gfi1 promoter to the same degree as WT GFI1B and the missense variants. However, it must be noted that we could only detect the truncated protein after proteasome inhibition, suggesting it is unstable (*Online Supplementary Figure S6*). If this is also the case in primary patient cells, the Q89fs variant would lead to haploinsufficiency. This variant was classified as VUS.

The R184P and H181Y variants stimulated MEG-01 proliferation and failed to repress endogenous GFI1B expression in a similar way to the pathogenic Q287* variant. These missense variants were absent from the gnomAD database and co-segregation studies were performed (Figure 3). Both the propositus (P6.1) and her father (P6.2), who are carriers of R184P, showed a small number of hypogranular platelets and platelet CD34 expression (*Online Supplementary Table S1* and *Online Supplementary Figures S3* and *S4*). P6.1 had a normal platelet count whereas her father (P6.2) had mild thrombocytopenia. Importantly, neither parent had clinical bleeding symptoms or platelet dysfunction (*Online Supplementary Table S1* and *Online Supplementary Figure S3A*). Following ACMG criteria, the R184P variant was classified as VUS. For the propositus (P5.1) with the H181Y variant, three affected relatives (P5.2, P5.4-5) and one non-affected (P5.3) relative were screened and the variant co-segregated with clinical bleeding symptoms, platelet dysfunction and CD34-positive platelets (*Online Supplementary Table S1* and *Online Supplementary Figure S3*). Affected individuals P5.1 and P5.2 had normal platelet counts with few large platelets and a significant reduction in α -granules (*Online Supplementary Table S1*

and *Online Supplementary Figures S4* and *S5*). The functional and segregation data suggest that the H181Y variant is the cause of bleeding and platelet dysfunction but does not result in thrombocytopenia. Following ACMG guidelines, H181Y was classified as a VUS (*Online Supplementary Table S1*).

We conclude that Q89fs, C168F, H181Y, and R184P affect GFI1B function, but are not necessarily sufficient to cause bleedings on their own. However, their identification and documentation, even when classified as VUS, will help to distinguish pathological from non-pathological GFI1B variants and increase our understanding of GFI1B functional domains. The identification of additional patients with similar variants will be essential to clarify their exact role in platelet phenotypes and bleeding.

Rinske van Oorschot,^{1*} Anna E. Marneth,^{1*} Saskia M. Bergevoet,¹ Maaike G.J.M. van Bergen¹ Kathelijne Peerlinck,² Claire E. Lentaigne,³ Carolyn M. Millar,^{3,4} Sarah K. Westbury,⁵ Remi Favier,⁶ Wendy N. Erber,^{7,8} Ernest Turro,^{9,10,11,12} Joop H. Jansen,¹ Willem H. Ouwehand,^{9,10,11,13,14,15} Harriet L. McKinney,^{9,10,11} NIHR BioResource Collaborative Group,¹¹ Kate Downes,^{9,10,11} Kathleen Freson^{2,11} and Bert A. van der Reijden¹

¹Department of Laboratory Medicine, Laboratory of Hematology, Radboudumc, Radboud Institute for Molecular Life Sciences (RIMLS), Nijmegen, the Netherlands; ²Department of Cardiovascular Sciences, Center for Molecular and Vascular Biology, University of Leuven, Belgium; ³Centre for Haematology, Hammersmith Campus, Imperial College Academic Health Sciences Centre, Imperial College London, UK; ⁴Imperial College Healthcare NHS Trust, London, UK; ⁵School of Cellular and Molecular Medicine, University of Bristol, UK; ⁶Service d'Hématologie Biologique, Assistance-Publique Hôpitaux de Paris, Centre de Référence des Pathologies Plaquettaires, Hôpital Armand Trousseau, Paris, France; ⁷School of Biomedical Sciences, University of Western Australia, Crawley, Western Australia, Australia; ⁸PathWest Laboratory Medicine, Nedlands, Western Australia, Australia; ⁹Department of Haematology, University of Cambridge, Cambridge Biomedical Campus, UK; ¹⁰National Health Service Blood and Transplant (NHSBT), Cambridge Biomedical Campus, UK; ¹¹NIHR BioResource, Cambridge University Hospitals, Cambridge Biomedical Campus, UK; ¹²Medical Research Council Biostatistics Unit, University of Cambridge, Forvie Site, Cambridge Biomedical Campus, UK; ¹³Department of Human Genetics, The Wellcome Trust Sanger Institute, Wellcome Trust Genome Campus, Hinxton, Cambridge, UK; ¹⁴Strangeways Research Laboratory, The National Institute for Health Research (NIHR) Blood and Transplant Unit in Donor Health and Genomics at the University of Cambridge, UK and ¹⁵BHF Centre of Excellence, Division of Cardiovascular Medicine, Addenbrooke's Hospital, Cambridge Biomedical Campus, UK

*RO and AEM contributed equally to this work.

Correspondence: BERT A. VAN DER REIJDEN
Bert.vanderReijden@radboudumc.nl
doi:10.3324/haematol.2018.207712

Information on authorship, contributions, and financial & other disclosures was provided by the authors and is available with the online version of this article at www.haematologica.org.

References

- Monteferrario D, Bolar NA, Marneth AE, et al. A dominant-negative GFI1B mutation in the gray platelet syndrome. *N Engl J Med.* 2014;370(3):245-253.
- Stevenson WS, Morel-Kopp MC, Chen Q, et al. GFI1B mutation causes a bleeding disorder with abnormal platelet function. *J Thromb Haemost.* 2013;11(11):2039-2047.
- Marneth AE, van Heerde WL, Hebeda KM, et al. Platelet CD34 expression and alpha/delta-granule abnormalities in GFI1B- and RUNX1-related familial bleeding disorders. *Blood.* 2017;129(12):1733-1736.
- Kitamura K, Okuno Y, Yoshida K, et al. Functional characterization

- of a novel GFI1B mutation causing congenital macrothrombocytopenia. *J Thromb Haemost.* 2016;14(7):1462-1469.
5. Uchiyama Y, Ogawa Y, Kunishima S, et al. A novel GFI1B mutation at the first zinc finger domain causes congenital macrothrombocytopenia. *Br J Haematol.* 2018;181(6):843-847.
 6. Ferreira CR, Chen D, Abraham SM, et al. Combined alpha-delta platelet storage pool deficiency is associated with mutations in GFI1B. *Mol Genet Metab.* 2017;120(3):288-294.
 7. Rabbolini DJ, Morel-Kopp MC, Chen Q, et al. Thrombocytopenia and CD34 expression is decoupled from alpha-granule deficiency with mutation of the first growth factor-independent 1B zinc finger. *J Thromb Haemost.* 2017;15(11):2245-2258.
 8. Schulze H, Schlagenhaut A, Manukjan G, et al. Recessive grey platelet-like syndrome with unaffected erythropoiesis in the absence of the Splice Isoform GFI1B-p37. *Haematologica.* 2017;102(9):e375-e378.
 9. Chen L, Kostadima M, Martens JH, et al. Transcriptional diversity during lineage commitment of human blood progenitors. *Science.* 2014;345(6204):1251033.
 10. van Oorschot R, Hansen M, Koornneef JM, et al. Molecular mechanisms of bleeding disorder-associated GFI1BQ287* mutation and its affected pathways in megakaryocytes and platelets. *Haematologica.* 2019;[Epub ahead of print].
 11. Anguita E, Villegas A, Iborra F, Hernandez A. GFI1B controls its own expression binding to multiple sites. *Haematologica.* 2010;95(1):36-46.
 12. Vassen L, Fiolka K, Mahlmann S, Moroy T. Direct transcriptional repression of the genes encoding the zinc-finger proteins Gfi1b and Gfi1 by Gfi1b. *Nucleic Acids Res.* 2005;33(3):987-998.
 13. Huang DY, Kuo YY, Chang ZF. GATA-1 mediates auto-regulation of Gfi-1B transcription in K562 cells. *Nucleic Acids Res.* 2005;33(16):5331-5342.
 14. Saleque S, Kim J, Rooke HM, Orkin SH. Epigenetic regulation of hematopoietic differentiation by Gfi-1 and Gfi-1b is mediated by the cofactors CoREST and LSD1. *Mol Cell.* 2007;27(4):562-572.
 15. Richards S, Aziz N, Bale S, et al. Standards and guidelines for the interpretation of sequence variants: a joint consensus recommendation of the American College of Medical Genetics and Genomics and the Association for Molecular Pathology. *Genet Med.* 2015;17(5):405-424.
 16. Westbury SK, Turro E, Greene D, et al. Human phenotype ontology annotation and cluster analysis to unravel genetic defects in 707 cases with unexplained bleeding and platelet disorders. *Genome Med.* 2015;7(1):36.